

V-BELT SELECTION GUIDE

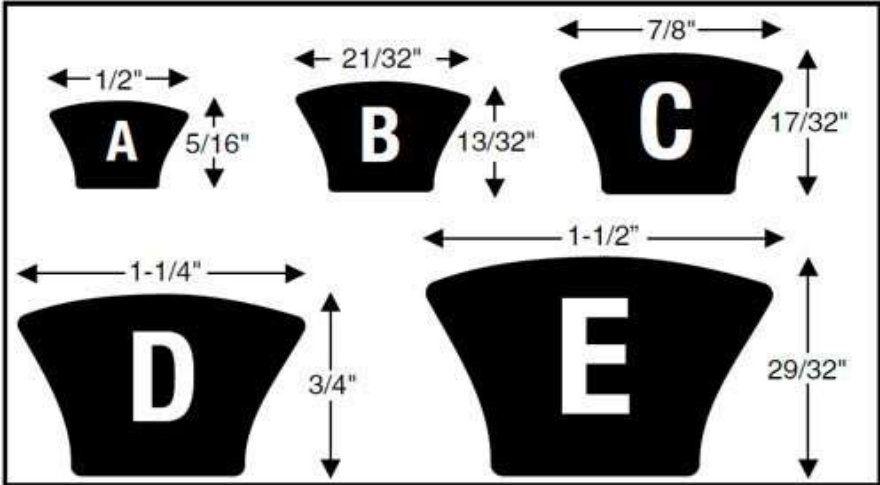

Classic V-Belt Profiles

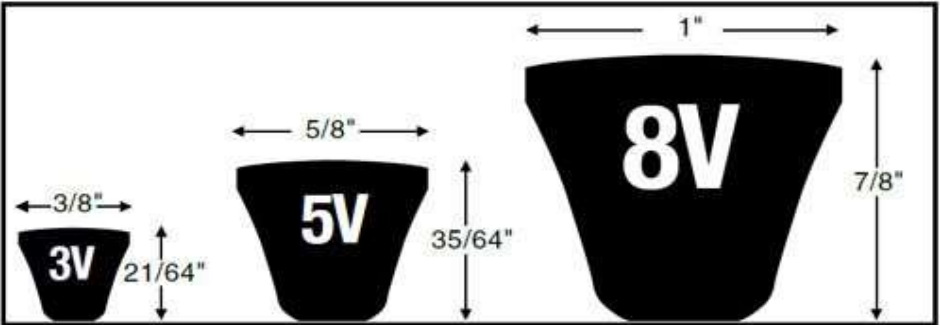

Narrow V-Belt Profiles

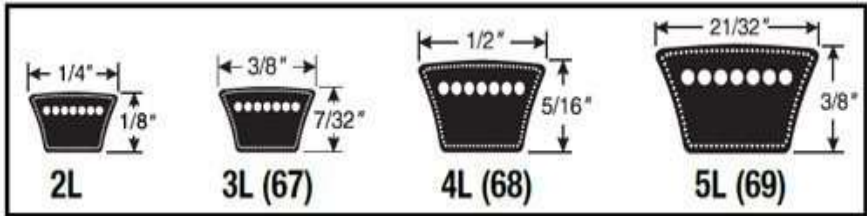

Fractional HP V-Belt Profiles

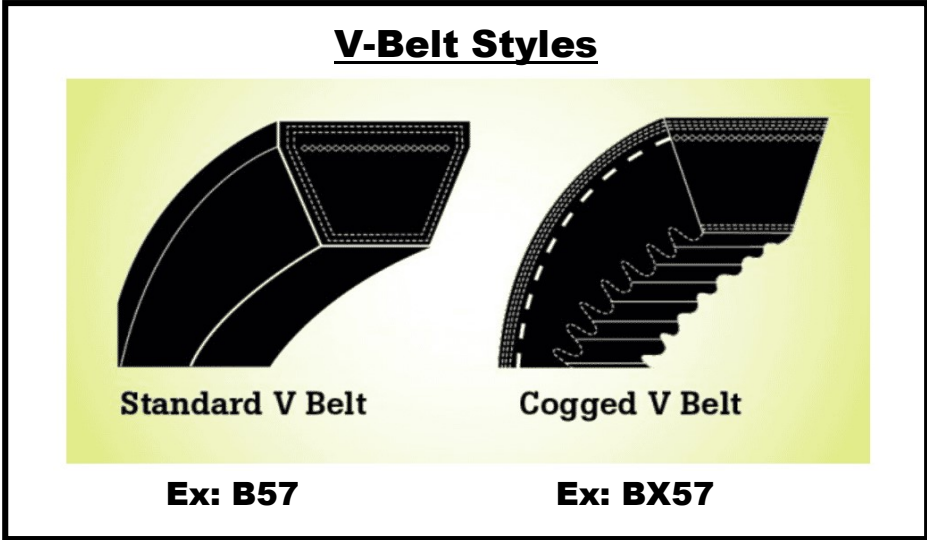

V-BELT LENGTH CALCULATION FORMULA

$$L_p = 2C + 1.57(D + d) + \frac{(D - d)^2}{4C}$$

